

Technical Data | Dimensions - figure 2301 - Full Bore

Gear operated valves - Class 150 lbs

Dimensions	4"	6"	8"	10"	12"	14"	16"	18"	20"	24"
A	432	534	635	788	915	864	889	1082	1220	1397
e**	11	12	12,7	14,5	16	16,6	17,5	18,2	19	20,6
Ba	370	428	478	524	556	605	641	680	741	828
Bb Closed	772	916	1149	1348	1410	1494	1684	1843	2027	2198
Bd Open	798	976	1209	1408	1470	1569	1759	1918	2115	2286
Be	489	559	654	676	890	1095	1156	1352	1553	2100
C	280	325	355	365	370	440	450	520	620	780
D	229	279	343	406	483	535	595	610	699	815
F	300	300	300	450	450	650	850	850	850	1000
H*	407	470	526	546	622	665	706	760	815	911
Turn open/close	27 1/2	36 1/2	36 1/2	36 1/2	36 1/2	46 1/2	46 1/2	41 1/2	41 1/2	41 1/2
CV	2173	5103	9450	16821	24570	30240	41580	65500	70875	105084
Gear Box	FL-0	FL-1	FL-1	FL-1	FL-2	FL-2	FL-2	FL-3	FL-3	FL3
Weight (Kg.)	250	440	580	660	1010	1290	1590	2280	2840	3360

e**= Shell wall thickness by API 6D

H*= Minimum space required under the valve in order to replace slips.

NOTE: Flanged ended as per ANSI B16,5 / EN-1092-1. The dimensions are shown in ANSI.

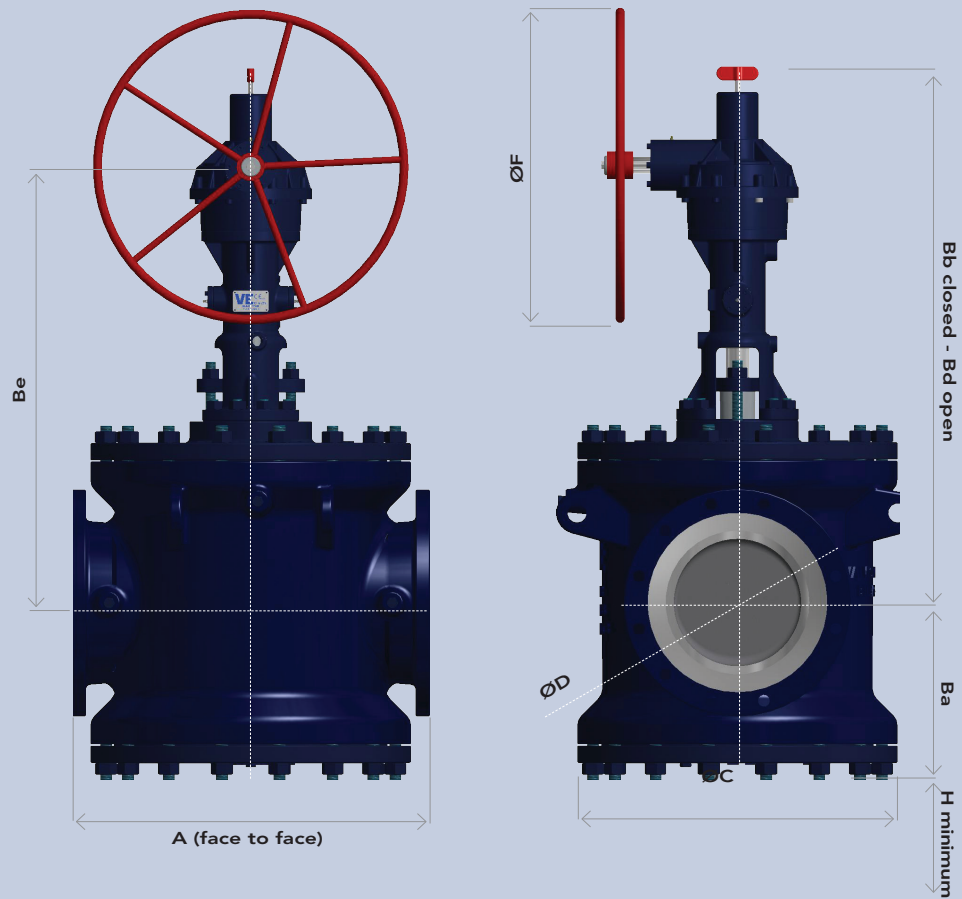

Technical Data | Dimensions - figure 2301 - Full Bore

Gear operated valves - Class 300 lbs

e**= Shell wall thickness by API 6D

H*= Minimum space required under the valve in order to replace slips.

NOTE: Flanged ended as per ANSI B16,5 / EN-1092-1. The dimensions are shown in ANSI.

Dimensions	4"	6"	8"	10"	12"	14"	16"
A	457	559	686	826	965	864	889
e**	12,7	16	17,5	19	20,6	22,2	25
Ba	370	428	478	524	566	610	641
Bb Closed	772	916	1149	1348	1410	1540	1648
Bd Open	798	975	1209	1423	1485	1615	1723
Be	460	594	854	1073	1114	1234	1304
C	280	325	355	365	370	410	450
D	257	318	381	445	520	580	650
F	300	450	650	650	850	850	850
H*	407	470	526	576	622	650	706
Turn open/close	27 1/2	36 1/2	36 1/2	46 1/2	46 1/2	46 1/2	46 1/2
CV	2079	5103	9450	16159	23625	29845	39690
Gear Box	FL-0	FL-1	FL-1	FL-2	FL-2	FL-3	FL-3
Weight (Kg.)	270	450	600	850	1085	1410	1830

Gear operated valves - Class 600 lbs

e**= Shell wall thickness by API 6D

H*= Minimum space required under the valve in order to replace slips.

NOTE: Flanged ended as per ANSI B16,5 / EN-1092-1. The dimensions are shown in ANSI.

Dimensions	4"	6"	8"	10"	12"
A	535	660	660	787	838
e**	16	19	25,4	28,5	31,7
Ba	370	275	340	395	445
Bb Closed	992	1148	1235	1435	2151
Bd Open	1050	1206	1310	1510	2239
Be	737	793	877	1081	1796
C	280	400	542	640	770
D	260	356	419	510	580
F	450	450	850	850	850
H*	407	430	470	590	710
Turn open/close	36 1/2	36 1/2	46 1/2	46 1/2	41 1/2
CV	1980	5103	9450	15890	22850
Gear Box	FL-1	FL-1	FL-2	FL-2	FL-2
Weight (Kg.)	370	610	795	1045	1445

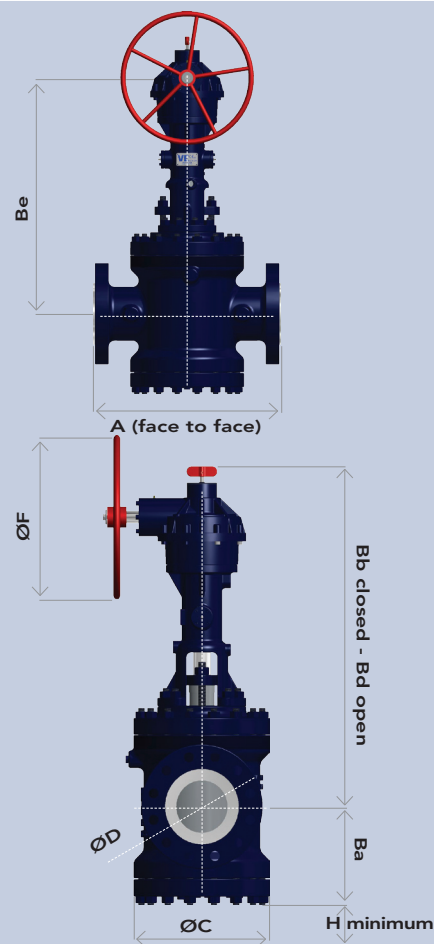

Technical Data | Dimensions - figure 2301 - Full Bore

Bare stem valves - Class 150 lbs

Dimensions	4"	6"	8"	10"	12"	14"	16"	18"	20"	24"
A	432	534	635	788	915	864	889	1082	1220	1397
e**	11	12	12,7	14,5	16	16,6	17,5	18,2	19	20,6
Ba	370	428	478	524	566	605	641	680	741	828
Bb	635	726	850	676	890	1095	1156	1320	1553	2100
C	280	325	355	365	370	440	450	520	620	780
D	229	257	343	406	483	507	580	610	635	710
H*	407	470	526	546	622	665	706	760	815	911
ISO 5210	F10	F14	F14	F14	F14	F16	F16	F25	F25	F25
Turn open/close	27 1/2	36 1/2	36 1/2	36 1/2	36 1/2	11 1/2	11 1/2	10 1/2	10 1/2	10 1/2
CV	2173	5103	9450	16821	24570	30240	41580	65500	70875	105084
Weight (Kg.)	220	390	530	620	970	1250	1550	2230	2790	3320

e**= Shell wall thickness by API 6D

H*= Minimum space required under the valve in order to replace slips.

NOTE: Flanged ended as per ANSI B16,5 / EN-1092-1. The dimensions are shown in ANSI.

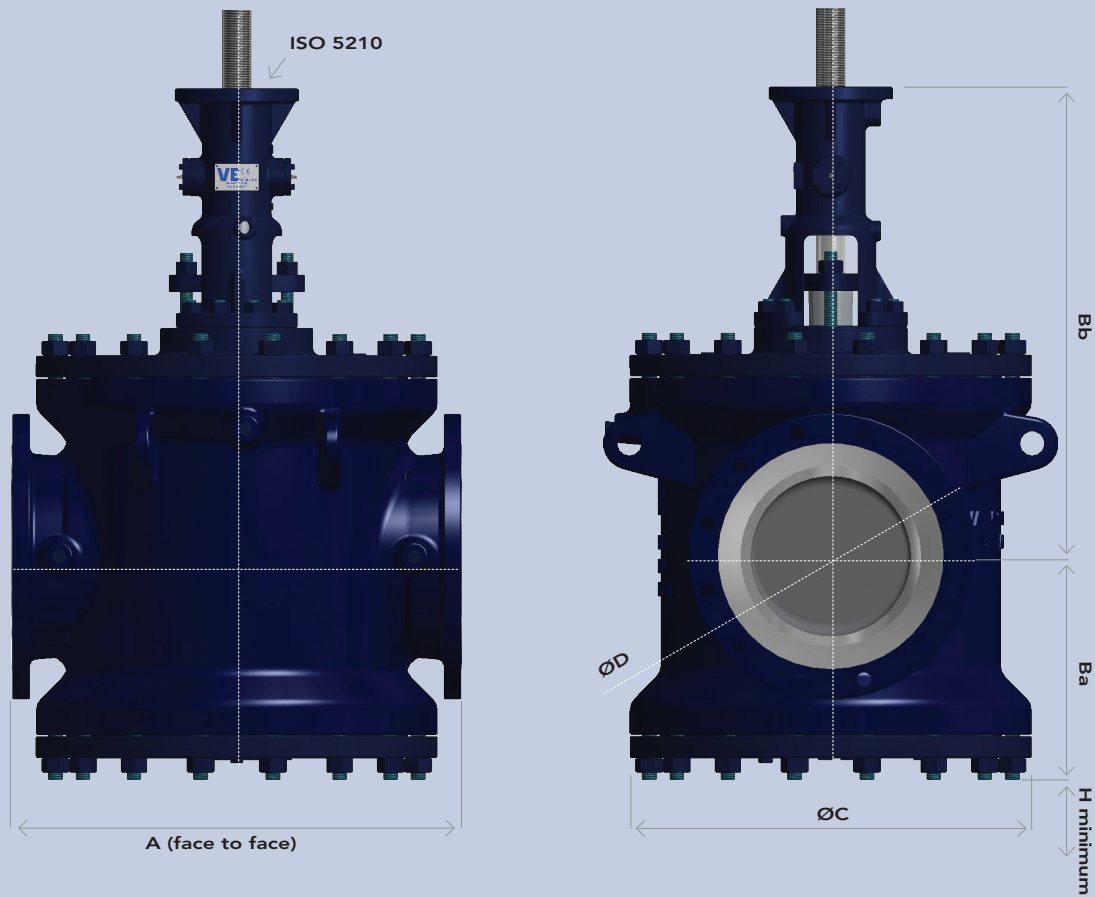

Technical Data | Dimensions - figure 2301 - Full Bore

Bare stem valves - Class 300 lbs

e**= Shell wall thickness by API 6D

H*= Minimum space required under the valve in order to replace slips.

NOTE: Flanged ended as per ANSI B16,5 / EN-1092-1. The dimensions are shown in ANSI.

Dimensions	4"	6"	8"	10"	12"	14"	16"
A	457	559	686	826	965	864	889
e**	12,7	16	17,5	19	20,6	22,2	25
Ba	370	428	478	524	566	605	641
Bb	416	772	1110	1395	1448	1570	1695
C	280	325	355	365	370	410	450
D	257	318	381	445	520	580	610
H*	407	470	526	576	622	650	706
ISO 5210	F10	F14	F14	F14	F16	F16	F16
Turn open/close	7	9	9	11 1/2	11 1/2	11 1/2	11 1/2
CV	2079	5103	9450	16159	23625	27565	39690
Weight (Kg.)	250	420	575	820	1020	1360	1780

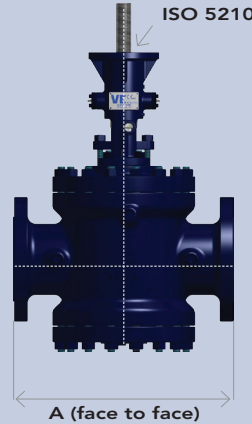
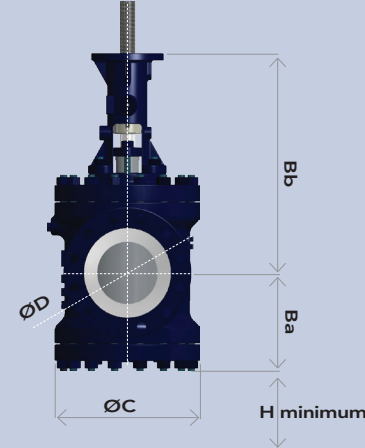



Bare stem valves - Class 600 lbs

e**= Shell wall thickness by API 6D

H*= Minimum space required under the valve in order to replace slips.

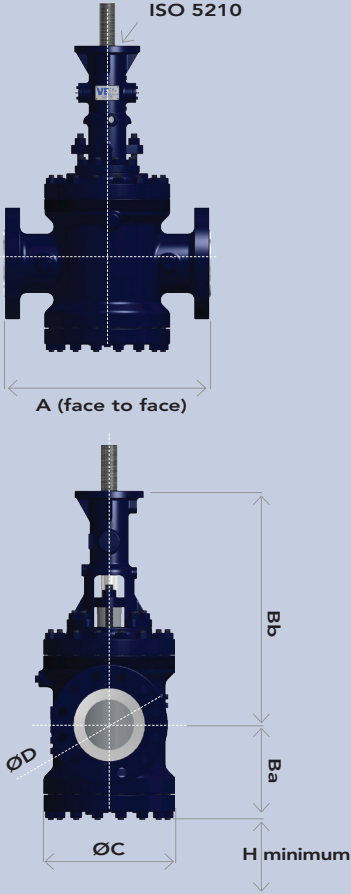
NOTE: Flanged ended as per ANSI B16,5 / EN-1092-1. The dimensions are shown in ANSI.

Dimensions	4"	6"	8"	10"	12"	
A	535	660	794	940	1215	
e**	16	19	25,4	28,5	31,7	
Ba	370	275	331	410	566	
Bb	635	691	741	945	1660	
C	280	400	542	640	770	
D	260	356	419	510	580	
H*	407	430	470	590	622	
ISO 5210	F14	F14	F16	F16	F25	
Turn open/close	9	9	11 1/2	11 1/2	10 1/2	
CV	1980	5103	9450	15890	22850	
Weight (Kg.)	340	580	765	1005	1405	